

TECHNICAL CATALOGUE:
MDLE

SIMPLICITY IN MOTION

MDLE

Reductora Para Extrusora De Tornillo Simple High Torque Gear Units For Single Screw Extruder

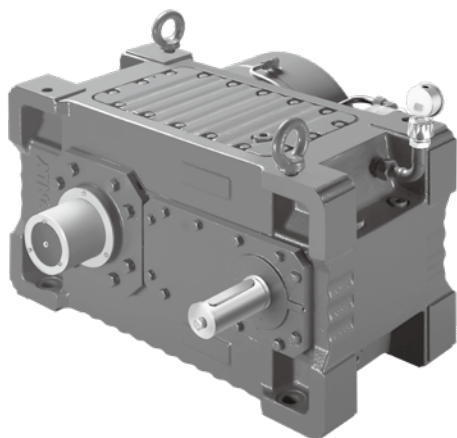

1. Descripción del producto Product Description

1.1 Características del producto01	Product features
1.2 Factor de servicio01	Working condition factor
1.3 Unión por tornillos01	Screw connection
1.4 Guía de selección02	Selection guideline
1.5 Observaciones03	Notes
1.6 Ejemplo de identificación03	Example designation

2. Tabla de parámetros del reductor Gear Units Parameter Table

2.1 Par de salida nominal del reductor04	Rated output torque of gear units
2.2 Potencia nominal del reductor05	Rated power of gear units
2.3 Potencia térmica del reductor06	Thermal capacity of gear units

3. Dimensiones exteriores y de montaje Outline And Mounting Dimensions

3.1 Plano de dimensiones exteriores y de montaje07	Outline and installation dimension drawing
3.2 Tabla de dimensiones exteriores y de montaje08	Outline and mounting dimensions table
3.3 Tabla de dimensiones de conexión entre el reductor y el motor .09	Connection dimension table between gear units and motors
3.4 Tabla de selección de reductores de alto par de la serie DLE ..10	Selection table of DLE series high torque gear units

Descripción del producto

1.1 Características del producto

- Los engranajes y los ejes de engranajes están fabricados en acero aleado de bajo contenido de carbono, de alta calidad y alta resistencia. Mediante cementación, temple y rectificado de precisión, se mejora considerablemente la capacidad de carga y la eficiencia de transmisión del reductor.
- Estructura de sellado especial que garantiza la ausencia de fugas.
- Sistema de lubricación y refrigeración de alta eficiencia, que mejora eficazmente la eficiencia de funcionamiento del conjunto y prolonga la vida útil de los componentes principales.
- El reductor está equipado con rodamientos de empuje de la serie 294**, que ofrecen una capacidad de carga axial extremadamente alta.
- La carcasa está fabricada en material de fundición de alta resistencia con excelentes propiedades de amortiguación, lo que reduce considerablemente el nivel de ruido del conjunto.
- Parámetros de engranaje optimizados que permiten una mayor transmisión de par; su capacidad de carga es más de un 60 % superior a la de los reductores de la serie ZLYJ del mismo tamaño.

1.2 Factor de servicio

La potencia transmitida y el par indicados en este manual se consideran sobre la base de un factor de servicio igual a 1. El cliente puede seleccionar el factor de servicio adecuado en función de las condiciones reales de funcionamiento. Para elegir el reductor más apropiado, se recomienda seleccionar un modelo con un factor de servicio $\geq 1,5$.

1.3 Unión de husillo

Según los requisitos normativos, puede seleccionarse una chaveta simple conforme a GB/T 1096 o una doble chaveta a 180°, así como estrías rectangulares conforme a GB/T 1144. Para cualquier cuestión relacionada con la conexión del husillo y el cilindro, póngase en contacto con nuestro departamento técnico.

Product Description

1.1 Product features

- The gear and gear shaft use high-quality high-strength low-carbon alloy copper, which is made by carburizing, quenching and precision grinding, which greatly improves carrying capacity and the transmission efficiency of gear units.
- Special sealing structure to ensure no leakage.
- Efficient cooling system effectively improves the working efficiency of the whole machine and the service life of main components.
- The gear units is equipped with 294** series thrust bearing with extremely high axial bearing capacity.
- The box body is made of casting material with high strength and good shock absorption performance, which greatly reduces the noise of the whole machine.
- The gear parameters are optimized, the transmission torque is greater, and the bearing capacity is 60% higher than that of ZLYJ series gear units of the same specification.

1.2 Working condition factor

The transmission work and torque shown in this manual are tested according to the working condition coefficient of 1. The working condition coefficient can be selected according to the specific service conditions. To select the most appropriate gear units, we recommend that the gear units model with coefficient greater than or equal to 1.5 be selected.

1.3 Screw connection

Single key of GB/T1096 or 180° double key can be selected according to the standard, and square spline of GB/T1144 can be selected. For any connection problem of screw barrel, please contact our technical department.

Descripción del producto

Product Description

1.4 Guía de selección

Ejemplo:

Para una extrusora de plástico de husillo simple, se requiere un reductor para un motor de potencia 110 kW.

El motor y el reductor están conectados mediante un acoplamiento. La velocidad del eje de entrada es $n_1 = 1500\text{rpm}$, y la velocidad del husillo es $n_2 = 121\text{rpm}$. El diámetro del husillo es $D = 75\text{mm}$, y la presión del husillo es $P_a = 50\text{MPa}$. Se requiere un factor de servicio $K_A = 1,6$. El reductor se instala en posición vertical, con los ejes de entrada y salida en el mismo lado, y el eje de entrada situado en la parte inferior.

La temperatura de funcionamiento del aceite del reductor no debe superar los 80°C . Seleccionar el reductor y los accesorios adecuados.

Selección del reductor:

Relación de transmisión $i=n_2/n_1=1500/121=12.40$, se selecciona la relación de transmisión nominal más próxima de 12,5.

Selección según la potencia

La potencia nominal de entrada requerida del reductor es $P_A=K_A \cdot P=1.6 \cdot 110=176\text{ kW}$, según la tabla 2, para una velocidad del eje de entrada $n_1=1500\text{rpm}$, la potencia nominal del modelo DLE2H08 es de 216 kW, que es superior a 176 kW, por lo tanto, cumple con los requisitos.

Comprobación de la potencia térmica

Según la tabla 3, la potencia térmica del reductor DLE2H08 es de 112 kW, ligeramente superior a la potencia del motor de 110 kW. Dado que se requiere que la temperatura de funcionamiento del aceite del reductor no supere los 80°C , es necesario equipar un sistema de refrigeración para realizar refrigeración forzada.

Comprobación de la vida útil del rodamiento

Según la carga axial:

$$F_a = \pi \times d_s \times d_s \times \frac{P_s}{4 \times 1000} = \pi \times 75 \times 75 \times \frac{50}{4 \times 1000} = 221\text{ kN}$$

El reductor DLE2H08 está equipado con el rodamiento de empuje modelo 29430E.

Según el catálogo de rodamientos, la carga dinámica nominal de dicho rodamiento es $C = 1452\text{ kN}$.

$$L_{h10} = \frac{10^6}{60 \times n_2} \times \left(\frac{C}{1.05 \times F_a} \right)^{\frac{10}{3}} = \frac{10^6}{60 \times 121} \times \left(\frac{1452}{1.05 \times 221} \right)^{\frac{10}{3}} = 62185\text{h}$$

Cumple con los requisitos

Forma de montaje del reductor

De acuerdo con los requisitos del usuario, el reductor se instala en posición vertical, con los ejes de entrada y salida en el mismo lado y con el eje de entrada situado en la parte inferior.

Se selecciona la forma de montaje tipo F.

Conclusión

El modelo final de reductor seleccionado es: DLE2H08-12.5-F-FJ02, equipado con lubricación y refrigeración forzada mediante bomba montada en el extremo del eje.

1.4 Selection guideline

Cases:

The gear units for plastic screw extruder is equipped with a motor power of 110kW, the coupling between the motor and the gear units.

The high-speed shaft speed $n_1=1500\text{rpm}$, the screw rod speed $n_2=121\text{rpm}$, the rod diameter $D=75\text{mm}$, the rod pressure $P_a=50\text{MPa}$, the required working condition $K_A=1.6$, the gear units is installed vertically, the input and output shafts are on the same side, and the input shaft is at the bottom, the working oil temperature of the gear units is not higher than 80°C . We need to select the appropriate gear units and accessories.

Gear units selection:

Speed ratio $i=n_2/n_1=1500/121=12.40$, select the nominal speed ratio nearest to 12.5.

Select according to power

It is required that the rated input power of the gear units $P_A=K_A \cdot P=1.6 \cdot 110=176\text{ kW}$, according to table 2, the high speed shaft speed $n_1=1500\text{rpm}$. When the speed ratio is 12.5, the rated power of DLE2H08 is 216kW, greater than 176kW.

Thermal capacity check

According to the table 3, the thermal capacity of DLE2H08 gear units is 112kW, which is slightly greater than the motor power of 110kW. Since the working oil temperature of the gear units is required not exceed 80°C , it is necessary to configure a cooler for forced cooling.

Thrust bearing life check

Axial load of thrust bearing:

The bearing model of DLE2H08 gear units is 29430E, check the bearing type record, and the fixed dynamic load of the bearing is $C=1452\text{kN}$.

The request is fulfilled.

Assembly form of gear units

The gear units is installed vertically according to the user requirements. The input and output shafts are on the same side, and the input shaft is at the bottom, and select the F assemble type.

Conclusion

Finally, DLE2H08-12.5-F-FJ02 gear units is selected, which is equipped with shaft end pump for forced lubrication and cooling.

Descripción del producto

Product Description

1.5 Observaciones

- La velocidad de rotación del eje de entrada no debe superar las 1800 rpm.
- La temperatura ambiente de funcionamiento es de -40°C a 45°C ; cuando es inferior a 0°C , el reductor debe ponerse en marcha en vacío para su precalentamiento.
- Las ilustraciones incluidas en el catálogo son únicamente ejemplos y no tienen carácter legalmente vinculante; la empresa se reserva el derecho de realizar modificaciones futuras.
- Los pesos indicados son valores de referencia y no son vinculantes.
- El reductor se suministra en condiciones aptas para el funcionamiento; antes de la puesta en marcha debe añadirse el aceite lubricante correspondiente.
- El sentido de giro por defecto del reductor es el siguiente: observando el eje de salida, éste gira en sentido horario.

1.5 Notes

- The input shaft speed shall not be greater than 1800rpm.
- The working environment temperature is -40°C to 45°C . If it is lower than 0°C , it shall be preheated by idling.
- The attached drawings in the sample only include examples and are not legally binding. The company reserves the right to change them in the future.
- The weight noted is a reference value and is not binding.
- The gear units has been allowed to operate after leaving the factory, and lubricating oil shall be filled before operation.
- The default rotation direction of the gear units is: when facing the output shaft, the output shaft rotates clockwise.

1.6 Ejemplo de identificación

1.6 Example designation:



Tabla de parámetros del reductor

Gear Units Parameter Table

2.1 Tabla 1 Par de salida nominal del reductor - Nm

2.1 Table 1 Rated output torque of gear units—Nm

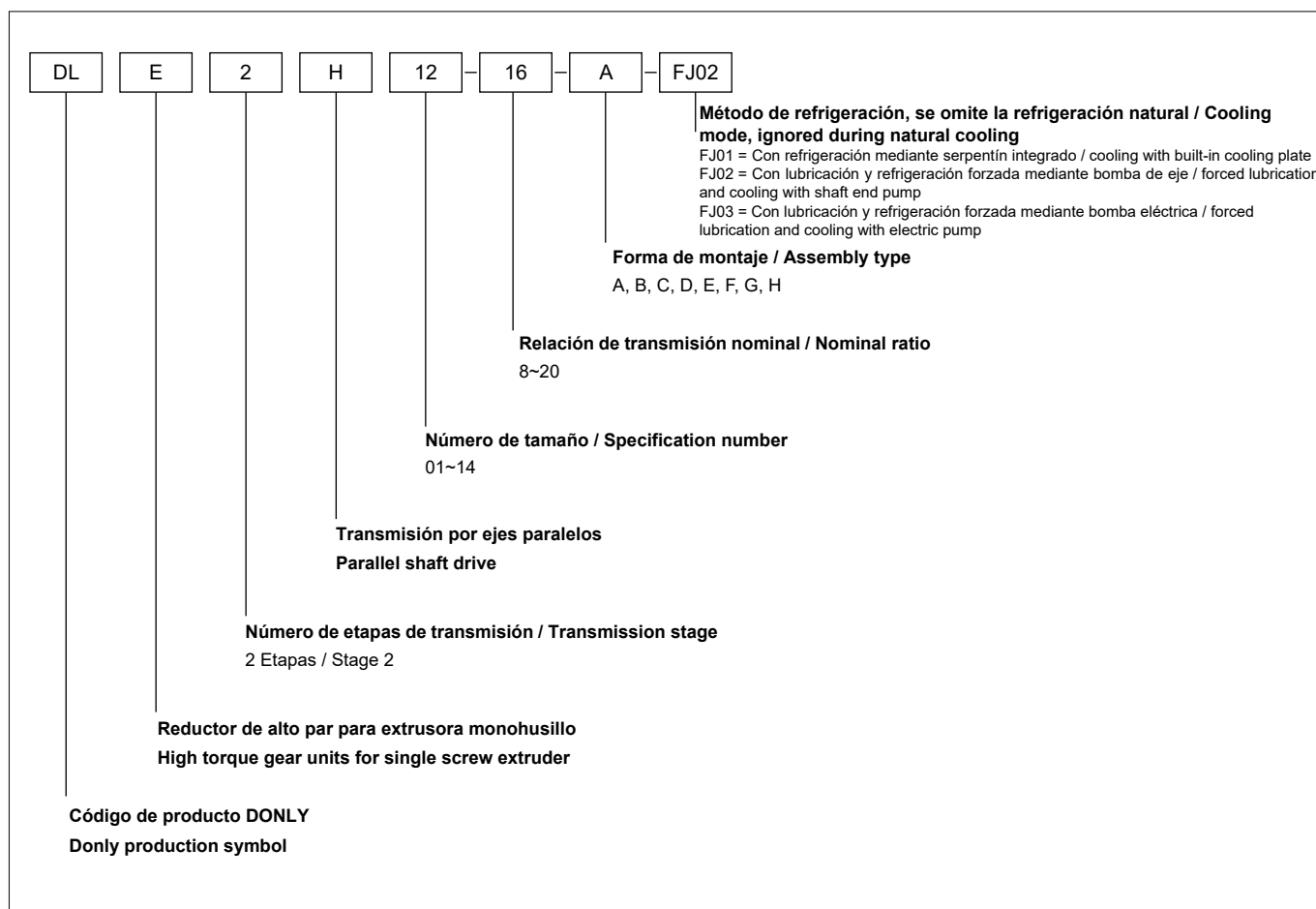
Modelo y tamaño Specification and model	Velocidad de entrada Input speed n_1 (rpm)	Relación de transmisión nominal / Nominal ratio								
		8	9	10	11.2	12.5	14	16	18	20
DLE2H01	1800	1440	1470	1460	1460	1390	1360	1490	1520	1410
	1500	1490	1570	1510	1510	1140	1420	1550	1560	1480
	1000	1520	1580	1560	1560	1480	1430	1610	1570	1500
	750	1490	1600	1570	1570	1490	1450	1620	1590	1510
DLE2H02	1800	2120	2280	2260	2290	2290	2200	2310	2260	2100
	1500	2180	2330	2290	2350	2340	2260	2320	2280	2160
	1000	2180	2320	2300	2340	2340	2270	2320	2260	2150
	750	2180	2320	2290	2340	2340	2270	2320	2280	2150
DLE2H03	1800	2930	3220	3140	3290	3210	3270	3150	3190	3100
	1500	2990	3310	3200	3340	3290	3360	3240	3250	3180
	1000	2990	3310	3200	3330	3290	3360	3250	3260	3180
	750	3000	3310	3200	3330	3290	3350	3250	3260	3180
DLE2H04	1800	4100	4580	4540	4630	4540	4470	4320	4520	4460
	1500	4180	4680	4620	4700	4650	4580	4430	4610	4520
	1000	4180	4680	4610	4710	4650	4570	4430	4620	4510
	750	4180	4690	4620	4710	4650	4570	4430	4610	4520
DLE2H05	1800	5730	6480	6320	6220	6460	6300	6510	6180	6390
	1500	5860	6630	6480	6340	6600	6450	6630	6310	6490
	1000	5860	6630	6480	6350	6600	6460	6630	6310	6490
	750	5860	6640	6480	6340	6590	6460	6630	6300	6490
DLE2H06	1800	8020	8710	9160	9060	9270	9120	8710	9240	9020
	1500	8190	8900	9360	9240	9450	9320	8870	8400	9190
	1000	8170	8890	9370	9230	9440	9320	8860	9410	9180
	750	8190	8890	9370	9230	9450	9320	8860	9410	9190
DLE2H07	1800	11200	12610	12210	11950	12250	12860	12460	12150	12210
	1500	11420	12890	12450	12220	12530	13130	12690	12370	12480
	1000	11420	12890	12450	12220	12530	13120	12700	12380	12470
	750	11420	12880	12450	12200	12530	13120	12700	12370	12490
DLE2H08	1800	16320	17330	17160	16830	16610	17560	17430	16590	17070
	1500	16670	17680	17490	17160	16980	17950	17770	16950	17440
	1000	16670	17670	17490	17160	16960	17940	17780	16950	17450
	750	16670	17680	17500	17160	16980	17940	17780	16940	17440
DLE2H09	1800	21520	24060	23290	24340	23990	23970	23820	23850	23270
	1500	21950	24570	23800	24870	24480	24480	24280	24320	23790
	1000	21950	24570	23800	24870	24480	24480	24290	24320	23780
	750	21950	24580	23790	24870	24490	24480	24270	24330	23780
DLE2H10	1800	30950	34780	34380	34950	34720	34150	34450	34630	33830
	1500	31590	35500	35080	35650	35460	34850	35140	35300	34490
	1000	31590	35500	35080	35650	35450	34850	35130	35300	34500
	750	31580	35490	35080	35650	35460	34850	35130	35300	34500
DLE2H11	1800	44340	50070	49250	51400	49860	51030	50130	51510	49540
	1500	45240	51110	50290	52480	50880	52060	51180	52580	50560
	1000	45240	51100	50290	52470	50880	52060	51190	52560	50560
	750	45240	51110	50290	52460	50890	52060	51190	52580	50570
DLE2H12	1800	62690	72130	71200	70020	69520	70850	69350	71090	69980
	1500	63990	73640	72670	71450	70950	72300	70780	72570	71400
	1000	63990	73640	72670	71450	70940	72290	70790	72540	71380
	750	63940	73620	72680	71460	70950	72290	70780	72570	71400
DLE2H13	1800	86690	99230	97570	101720	98970	101320	99580	100120	97970
	1500	88480	101290	99590	103820	100990	103410	101610	102200	99980
	1000	88410	101210	99580	103760	100960	103390	101470	102070	99910
	750	88390	101220	99470	103820	100910	103370	101490	102110	99990
DLE2H14	1800	127848	142966	140296	144885	142728	140142	141374	142207	138845
	1500	130470	145880	143780	147860	145650	142975	144240	145070	141675
	1000	130460	145885	143765	147860	145660	142940	144205	145075	141585
	750	130480	145935	143790	147860	145725	143070	144225	144995	141555

Nota:

El par de salida nominal indicado anteriormente se considera sobre la base de un factor de servicio igual a 1. El cliente puede seleccionar el factor de servicio adecuado en función de las condiciones reales de funcionamiento. Para elegir el reductor más apropiado, se recomienda seleccionar un modelo con un factor de servicio ≥ 1.5 .

Note:

The above rated output torque is considered according to the working condition coefficient of 1. The customers can select the appropriate working condition coefficient according to the specific service conditions. In order to select the most appropriate gear units, we suggest selecting the gear units model with the coefficient greater than or equal to 1.5.

Tabla de parámetros del reductor

Gear Units Parameter Table

2.2 Tabla 2 Potencia nominal del reductor - kW

2.2 Table 2 Rated power of gear units—kW

Modelo y tamaño Specification and model	Velocidad de entrada Input speed n_1 (rpm)	Relación de transmisión nominal / Nominal ratio								
		8	9	10	11.2	12.5	14	16	18	20
DLE2H01	1800	32	29	27	25	22	19	18	17	14
	1500	28	25	23	22	19	17	16	14	11
	1000	19	17	15	14	13	11	11	10	8
	750	14	13	12	11	10	9	8	8	6
DLE2H02	1800	50	48	42	39	36	30	28	25	20
	1500	42	42	36	33	31	25	23	21	17
	1000	28	28	24	22	21	17	16	14	11
	750	21	21	18	17	15	13	12	11	8
DLE2H03	1800	73	70	59	56	50	46	38	34	31
	1500	62	60	50	47	43	39	32	29	26
	1000	41	40	33	31	29	26	22	19	17
	750	31	30	25	24	22	22	16	15	13
DLE2H04	1800	100	98	90	77	70	64	50	49	44
	1500	85	83	76	65	60	55	43	41	37
	1000	57	56	51	44	40	36	29	28	25
	750	42	40	38	33	30	27	22	21	19
DLE2H05	1800	140	136	122	111	97	87	81	65	62
	1500	119	116	104	94	83	74	69	55	53
	1000	79	77	70	63	55	50	46	37	35
	750	59	58	52	47	41	37	34	28	26
DLE2H06	1800	194	185	177	162	138	125	101	97	87
	1500	166	166	151	138	117	107	86	82	74
	1000	110	110	101	92	78	71	57	55	49
	750	83	83	76	69	59	53	43	41	37
DLE2H07	1800	280	275	228	205	185	180	149	134	116
	1500	238	234	193	175	157	153	127	114	99
	1000	159	156	129	117	105	102	85	76	66
	750	119	117	97	87	79	77	63	57	50
DLE2H08	1800	389	383	328	297	254	250	214	174	170
	1500	331	326	278	252	216	213	182	148	145
	1000	221	217	186	168	144	142	121	99	97
	750	166	163	139	126	108	107	91	74	72
DLE2H09	1800	536	524	434	413	377	337	286	256	230
	1500	455	446	369	352	321	287	243	217	196
	1000	303	297	246	235	214	191	162	145	130
	750	228	223	185	176	160	143	122	109	98
DLE2H10	1800	754	744	681	584	537	488	408	373	335
	1500	641	633	579	497	457	415	347	317	284
	1000	428	422	386	331	305	277	231	211	190
	750	321	317	290	248	229	207	173	158	142
DLE2H11	1800	1058	1049	953	905	751	688	624	572	467
	1500	900	893	811	770	638	584	531	486	397
	1000	600	595	541	513	426	390	354	324	265
	750	450	446	406	385	319	292	265	243	199
DLE2H12	1800	1520	1507	1378	1252	1114	972	876	748	678
	1500	1293	1282	1172	1064	948	827	745	636	576
	1000	862	855	781	710	632	551	497	424	384
	750	646	641	586	532	474	413	372	318	288
DLE2H13	1800	2129	2077	1877	1796	1481	1364	1231	1067	955
	1500	1810	1767	1596	1528	1259	1160	1047	907	812
	1000	1206	1177	1064	1018	839	773	697	604	541
	750	904	883	797	764	629	580	523	453	406
DLE2H14	1800	3041	2995	2724	2363	2148	1940	1618	1427	1276
	1500	2586	2547	2316	2010	1827	1649	1376	1213	1085
	1000	1724	1698	1544	1340	1218	1099	917	809	723
	750	1293	1274	1158	1005	914	825	688	606	542

Nota:

El par de salida nominal indicado anteriormente se considera sobre la base de un factor de servicio igual a 1. El cliente puede seleccionar el factor de servicio adecuado en función de las condiciones reales de funcionamiento. Para elegir el reductor más apropiado, se recomienda seleccionar un modelo con un factor de servicio ≥ 1.5 .

Note:

the above rated power is considered according to the working condition coefficient of 1. The customers can select the appropriate working condition coefficient according to the specific service conditions. In order to select the most appropriate gear units, we suggest selecting the gear units model with the coefficient greater than or equal to 1.5.

Tabla de parámetros del reductor
Gear Units Parameter Table
2.3 Tabla 3 Potencia térmica del reductor - kW
2.3 Table 3 Thermal capacity of gear units—kW

Modelo Model	Velocidad de rotación del eje de entrada n_1 (rpm) / Input shaft speed n_1 (rpm)			
	1800	1500	1000	750
DLE2H01	15	16	16	17
DLE2H02	20	22	22	23
DLE2H03	31	34	35	35
DLE2H04	41	45	46	47
DLE2H05	53	58	59	60
DLE2H06	67	73	74	76
DLE2H07	83	90	92	94
DLE2H08	103	112	114	116
DLE2H09	128	139	142	145
DLE2H10	157	171	174	178
DLE2H11	190	207	211	215
DLE2H12	240	261	266	271
DLE2H13	299	325	332	338
DLE2H14	377	410	418	426

1. La potencia térmica básica indicada en la tabla se basa en una temperatura ambiente de 30 °C, una temperatura del aceite en régimen estacionario de 100 °C y una altitud de 1000 m.
2. Si la potencia térmica requerida es superior a los valores indicados en la tabla, debe utilizarse un sistema de refrigeración forzada.

1. The basic thermal capacity listed in the table is based on the ambient temperature of 30°C, the balanced oil temperature of 100°C and the altitude of 1000m.
2. If the thermal power demand is greater than the data listed in the table, the forced cooling system must be selected.

3.1 Plano de dimensiones exteriores y de montaje

3.1 Outline and installation dimension drawing

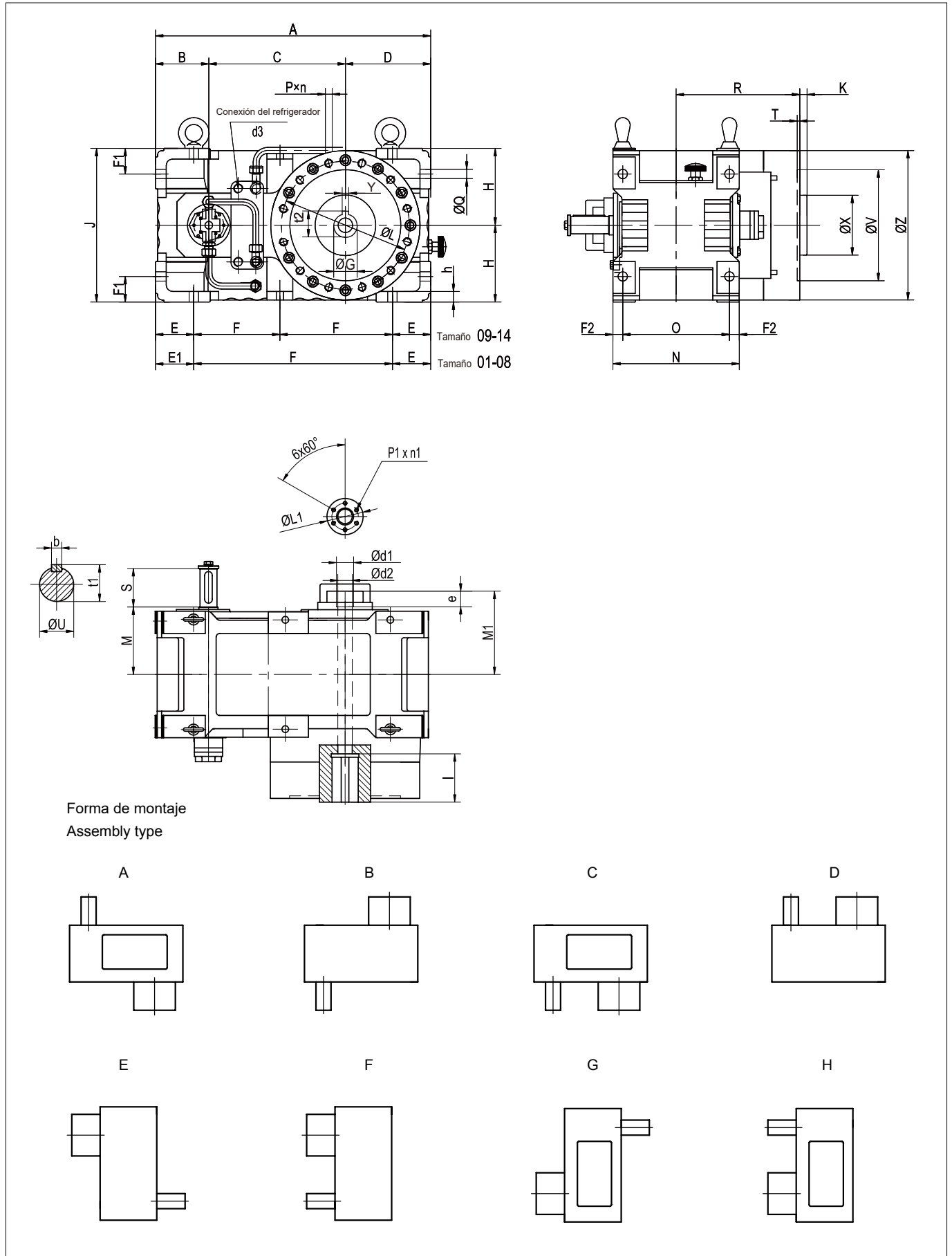

Dimensiones exteriores y de montaje

Outline And Mounting Dimensions

3.2 Tabla de dimensiones exteriores y de montaje

3.2 Outline and mounting dimension table

Modelo Model	A	B	C	D	d1	d2	d3	E	E1	e	F	F1	F2	G H7	H h12	h	I	J	K	L	L1	M
DLE2H01	355	63	180	112	20	18	R1/2	40	40	8	275	40	12	28	100	15	70	200	8	160	30	85
DLE2H02	407	80	202	125	22	19	R1/2	45	55	8	307	42	18	32	112	16	90	224	8	170	35	106
DLE2H03	455	90	225	140	28	24	R1/2	50	60	8	345	45	17	38	125	17	100	250	8	205	42	114
DLE2H04	512	100	252	160	30	27	R1/2	56	66	10	390	48	18	42	140	18	110	280	8	230	45	125
DLE2H05	577	112	285	180	32	29	R1/2	63	75	10	439	50	20.5	50	160	21	130	320	17	260	50	142
DLE2H06	645	125	320	200	40	34	R1/2	70	83	10	492	60	23	60	180	25	140	360	17	300	62	158
DLE2H07	725	140	360	225	50	44	R1/2	80	95	10	550	70	25	70	200	31	150	400	18	330	72	176
DLE2H08	795	140	405	250	60	55	R3/4	90	90	10	615	80	22.5	80	225	36	160	450	18	350	82	192
DLE2H09	890	160	450	280	70	55	R3/4	100	-	10	345	90	26	90	250	40	170	500	20	400	95	216
DLE2H10	1000	180	505	315	80	60	R3/4	112	-	10	388	100	30	100	280	48	190	560	20	450	105	242
DLE2H11	1125	200	570	355	90	60	R3/4	125	-	10	437.5	112	35	110	315	54	200	630	20	500	115	273
DLE2H12	1265	225	640	400	100	80	R3/4	140	-	10	492.5	125	40	125	355	55	210	710	24	600	140	302
DLE2H13	1420	250	720	450	110	80	R3/4	160	-	10	550	140	45	140	400	60	220	800	24	680	150	340
DLE2H14	1590	280	810	500	130	80	R3/4	180	-	10	615	150	55	160	450	65	240	900	24	780	180	390

Modelo Model	M1	N	n	n1	O	P	P1	Q	R	S	T	b	t1	t2	U	V H7	Y	X	Z	Rodamiento de empuje Thrust bearing model	Peso weight kg	Cantidad de aceite Oil quantity L
DLE2H01	95	164	8	6	140	M12	M4	12	170	50	5	6	24.5	31.3	22j6	140	8	60	180	29412E	60	3
DLE2H02	115	196	8	6	160	M12	M5	14	180	56	5	8	27	35.3	24j6	150	10	70	200	29412E	82	4
DLE2H03	125	214	8	6	180	M12	M6	16	205	63	5	8	31	41.3	28j6	180	10	80	230	29415E	112	5
DLE2H04	135	236	8	6	200	M12	M6	18	230	70	5	10	35	45.3	32j6	200	12	90	260	29417E	152	6
DLE2H05	155	266	8	6	225	M16	M8	20	260	80	6	10	38	53.8	35j6	230	14	110	300	29420E	218	9
DLE2H06	170	296	8	6	250	M20	M10	22	290	90	6	12	43	64.4	40k6	260	18	140	350	29424E	320	12
DLE2H07	190	330	8	6	280	M20	M10	24	320	100	6	14	48.5	74.9	45k6	290	20	160	380	29428E	465	16
DLE2H08	220	360	12	6	315	M20	M10	27	365	112	6	14	53.5	85.4	50k6	310	22	170	400	29430E	595	21
DLE2H09	240	407	12	6	355	M24	M10	30	405	125	8	16	59	95.4	55m6	365	25	190	450	29434E	850	30
DLE2H10	260	460	12	8	400	M24	M10	33	445	140	8	18	64	106.4	60m6	400	28	200	520	29436E	1240	40
DLE2H11	290	520	12	8	450	M24	M12	36	490	160	8	20	74.5	116.4	70m6	450	28	210	570	29440E	1700	68
DLE2H12	350	580	12	8	500	M30	M12	39	560	180	10	22	85	132.4	80m6	520	32	280	680	29452E	2530	98
DLE2H13	390	650	12	8	560	M36	M16	42	640	200	10	25	95	148.4	90m6	600	36	300	750	29456E	3550	120
DLE2H14	440	740	16	8	630	M36	M16	44	720	225	12	28	106	169.4	100m6	700	40	350	870	29468E	5150	195

1. El peso indicado en la tabla es un valor de referencia y puede variar en función de la relación de transmisión y de otras configuraciones requeridas.
2. La cantidad de aceite indicada en la tabla se basa en el montaje horizontal con sistema de lubricación por salpicadura.

1. The weights in the table are for reference and will change due to different reduction ratios and other required configurations.
2. The oil quantity in the table is based on the splash lubrication system when installed horizontally.

Dimensiones exteriores y de montaje

Outline And Mounting Dimensions

3.3 Tabla de dimensiones de conexión entre el reductor y el motor

3.3 Connection dimension table between gear units and motors

Tipo Type	Tabla de dimensiones Dimension table						Acoplamiento y soporte de conexión Coupling and connecting seat				
	A	B	C	E	F	Pxn	D	Y	t	I	H
C 200x24	200	165	130	4.5	10	M10x4	24	8	27.3	50	140
C 200x28							28	8	31.3	60	
C 250x28	250	215	180	5	12	M12x4	28	8	31.3	60	170
C 250x32							32	10	35.3	80	
C 300x38	300	265	230	5	14	M12x4	38	10	41.3	80	215
C 300x42							42	12	45.3	110	
C 350x42	350	300	250	6	15	M16x4	42	12	45.3	110	215
C 350x48							48	14	51.8	110	
C 350x55							55	16	59.3	110	
C 400x55	400	350	300	6	16	M16x4	55	16	59.3	110	(245)
C 400x60							60	18	64.4	140	280
C 400x65							65	18	69.4	140	(220)
C 450x60	450	400	350	8	18	M16x4	60	18	64.4	140	(260)
C 450x65							65	18	69.4	140	
C 450x70							70	20	74.9	140	
C 450x75							75	20	79.9	140	
C 500x65	500	500	450	8	20	M16x4	65	18	69.4	140	(305)
C 500x70							70	20	74.9	140	
C 500x75							75	20	79.9	140	
C 500x80							80	22	85.4	170	
C 660x80	660	600	550	8	24	M20x4	80	22	85.4	170	362
C 800x100	800	740	680	9	28	M22x4	-	-	-	-	-

Conjunto del reductor con acoplamiento y soporte de conexión

Combination of gear units, coupling and connecting seat

Tipo Type	DLE2H01	DLE2H02	DLE2H03	DLE2H04	DLE2H05	DLE2H06	DLE2H07	DLE2H08	DLE2H09	DLE2H10	DLE2H11	DLE2H12
C 200x24	※	※										
C 200x28	※	※										
C 250x28	※	※	※									
C 250x32	※	※	※									
C 300x38	※	※	※	※								
C 300x42			※	※	※							
C 350x42			※	※	※	※						
C 350x48			※	※	※	※						
C 350x55			※	※	※	※	※					
C 400x55				※	※	※	※	※				
C 400x60					※	※	※	※	※			
C 400x65						※	※	※	※	※		
C 450x60						※	※	※	※	※		
C 450x65							※	※	※	※		
C 450x70							※	※	※	※		
C 450x75								※	※	※	※	※
C 500x65								※	※	※	※	※
C 500x70								※	※	※	※	※
C 500x75									※	※	※	※
C 500x80									※	※	※	※
C 660x80											※	※
C 800x100												※

Dimensiones exteriores y de montaje
Outline And Mounting Dimensions
3.4 Tabla de selección de reductores de alto par de la serie DLE
3.4 Selection table of DLE series high torque gear units

Información de usuario / User information			
Nombre del usuario User name		Datos de contacto Contact information	
Parámetros del motor Motor parameter			
Modelo y tamaño del motor Motor specification and model		Velocidad del motor (rpm) Motor speed (rpm)	
Potencia del motor (kW) Motor power (kW)		Otros Other	
Parámetros y condiciones de funcionamiento del husillo / Screw parameters and working conditions			
Medio de trabajo Working medium	<input type="checkbox"/> Plastico / Plastic	<input type="checkbox"/> Caucho / Rubber	
Diámetro del husillo Screw diameter		Velocidad del husillo Screw speed	
Presión de trabajo Working pressure		Temperatura ambiente (°C) Ambient temperature (°C)	
Tiempo de funcionamiento diario Daily running time		Otros Other	
Método de conexión entre el motor y el reductor / Connection mode between motor and gear units			
Conexión directa mediante acoplamiento Coupling direct connection		Relación de transmisión por correa tipo "V" "V" type belt transmission speed ratio	
Requisitos especiales Special requirements			



C/ Italia 11 Nave 9
Pol. Ind. Les Comes
08700 - Igualada
(Barcelona) - Spain
+34 93 805 60 21
info@msgdrives.com
msgdrives.com